

PLB-AC Amber Series

HIGH EFFICIENCY LED BOLLARD

FIRSTLIGHT
TECHNOLOGIES

Project: _____

Type: _____

Quantity: _____



The PLB-AC Amber Series high efficiency LED bollard is ideal for pathway, egress and public space lighting applications. The stylish, contemporary design makes it a perfect fit for any new construction, renovation, or retrofit project that requires exceptional, full cutoff lighting performance with maximum energy savings.

With high performance LED technology and optics, the PLB-AC Amber Series offers significant benefits:

- High efficacy and ultra-low power consumption
- Asymmetrical and symmetrical light distributions
- Full cutoff optical performance
- Maintenance free with no bulbs or ballasts to change
- Robust, vandal resistant design

Approved by the Florida Fish and Wildlife Conservation Commission and the U.S. Fish and Wildlife Service through their Wildlife Lighting Certification Program, the PLB-AC Amber Series minimizes adverse impacts of lighting on wildlife. The amber LED, 180 degree backlight shield and low mounting height options reduces light pollution.

TECHNICAL SPECIFICATIONS

LEDs & Optics:

- High output Cree LEDs
- Amber LED (585nm to 595nm)
- High efficiency Type 3 distribution
- All distributions full cutoff
- Greater than 100,000 hours L70 lifetime LEDs
- Optional backlight shield
- 270 lumens for Type 3 Optic

Driver:

- 10W power consumption
- >0.98 power factor at full load
- 110 ~ 277 VAC, 47 ~ 63Hz input range
- OCP, SCP, OVP protection, auto recovery
- AC Phase - trailing-edge dimming compatible
- >100,000 hour MTBF

Mechanical Construction:

- Cast, marine-grade, corrosion resistant aluminum housing
- Extruded marine-grade aluminum post
- Stainless fasteners with security feature option
- High-strength mourning base
- Architectural grade, super durable TGIC powder coat
- Four standard colors with custom colors available
- IP67 protection

Warranty & Certification:

- 5 year limited warranty
- CSA C22.2 No. 250.0-08 - ANSI/ UL Standard 1598
- ANSI/ UL Standard 8750
- CSA C22.2 No. 250.13-14
- LED Lighting Facts Verification Tested
- Certified by the Florida Fish and Wildlife Conservation Commission

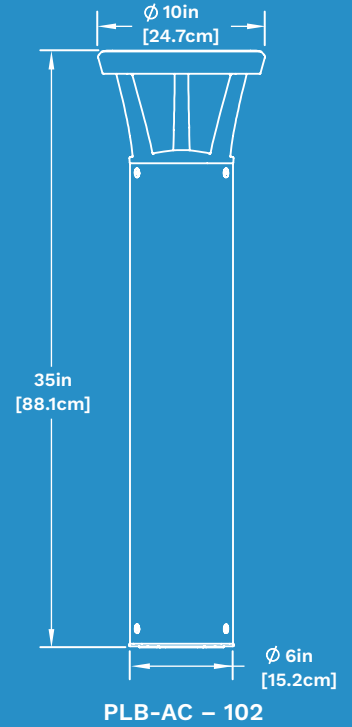
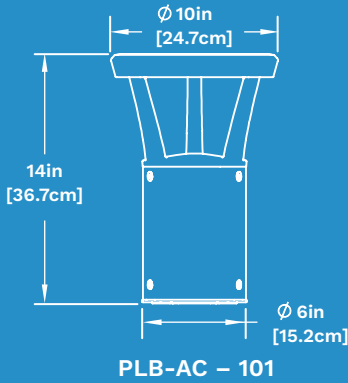
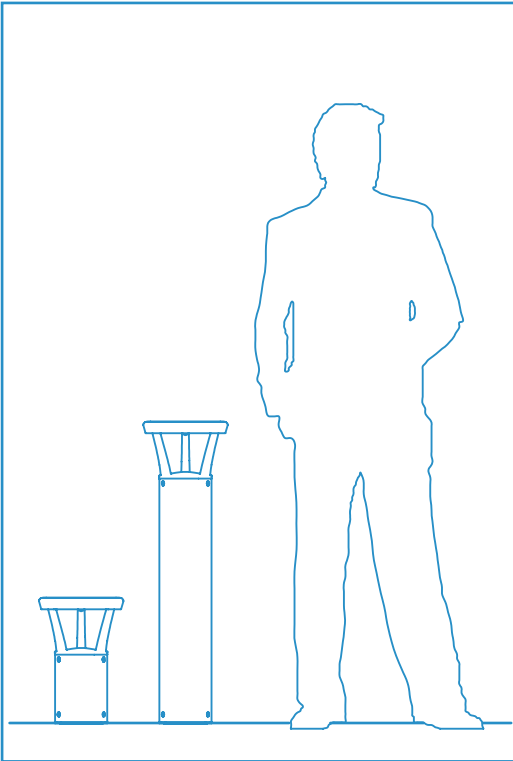

PHOTOMETRICS (IES files available on website)

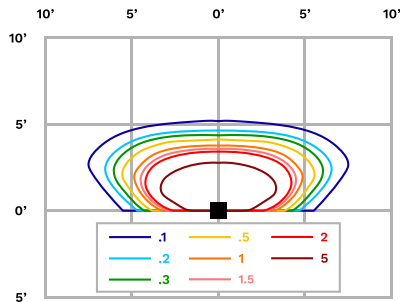

PLB-AC 101 - ASM Amber

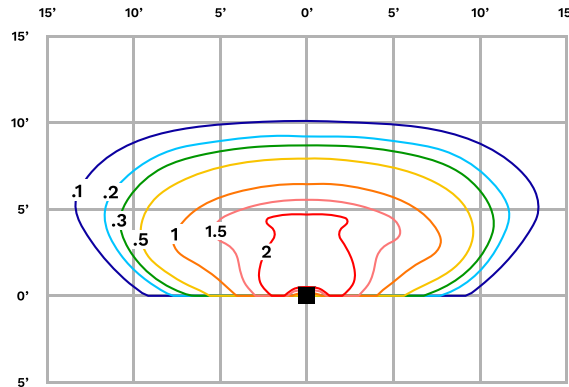

PLB-AC 102 - ASM Amber

Notes:

- All light levels in foot candles (fc)
- To convert to lux multiply light level by 10.7
- Specifications subject to change without notice

ORDER MATRIX



Series	Height	Finish	Distribution	LED	Voltage	Options
PLBAC	101 - 14"	BK - Black	ASM - Type 3	AMB - Amber	UV7 - Universal Voltage (700mA)	SEC - Security Fasteners
	102 - 36"	BZ - Bronze				PA - Pre-Ship Anchor Bolts
		SV - Silver				BLS - Backlight Shield
		WH - White				
		CC - Custom				